

OMC[®] Zephyr[™]

SAIL DRIVE

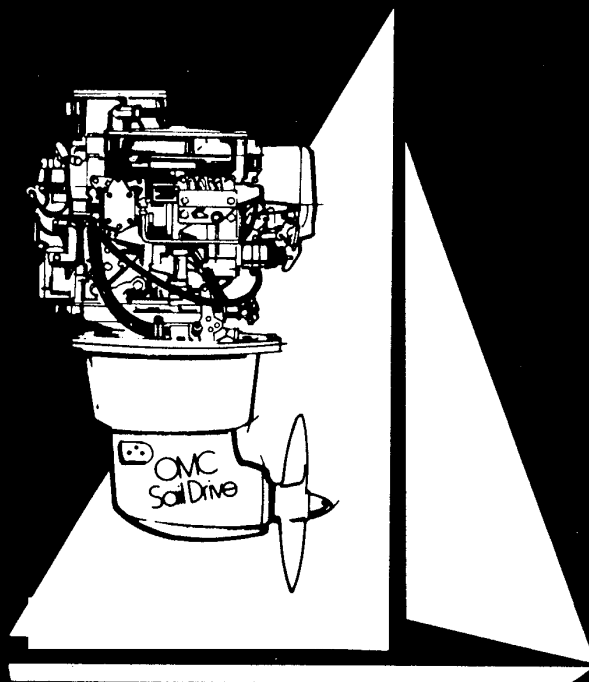

15S11C

parts
catalog

 **SAFETY WARNING**

DO NOT SUBSTITUTE AUTOMOTIVE PARTS FOR THE FOLLOWING MARINE COMPONENTS STARTER, ALTERNATOR, VOLTAGE REGULATOR, DISTRIBUTOR AND RELATED IGNITION PARTS, SPARK PLUG LEADS, SOLENOIDS, CARBURETOR (AND RELATED PARTS) OR FUEL PUMP.

THESE COMPONENTS HAVE BEEN SPECIFICALLY DESIGNED NOT TO EMIT FUEL VAPORS OR TO CAUSE IGNITION OF FUEL VAPORS IN THE BILGE

TO PREVENT AN ACCIDENT - DO NOT SUBSTITUTE AUTOMOTIVE COMPONENTS OR PARTS

WHEN REPLACEMENT PARTS ARE REQUIRED, USE GENUINE OMC PARTS OR PARTS WITH EQUIVALENT CHARACTERISTICS INCLUDING TYPE, STRENGTH, AND MATERIAL FAILURE TO DO SO MAY RESULT IN PRODUCT MALFUNCTION AND POSSIBLE INJURY TO THE OPERATOR AND/OR PASSENGERS.

 **NOTE**

THIS PARTS CATALOG SHOULD NOT BE USED IN LIEU OF A SERVICE MANUAL ORDER YOUR SERVICE MANUAL FROM

OMC STERN DRIVE
3815 GRANDVILLE AVENUE
GURNEE, ILLINOIS 60031
ATTN SERVICE DEPARTMENT

SUPPLY ENGINE MODEL AND SERIAL NUMBER FROM THE ENGINE VALVE COVER WHEN REQUESTING A SERVICE MANUAL

OMC Stern Drive, a division of Outboard Marine Corporation, reserves the right to make changes at any time, without notice, in specifications and models and also to discontinue models. The right is also reserved to change any specifications or parts at any time without incurring any obligation to equip same on models manufactured prior to date of such change.

While the information contained in this Parts Catalog is based on the latest product information available at the time of publication, the continuing accuracy of this Parts Catalog cannot be guaranteed

All illustrations used in this Parts Catalog may not depict actual models or equipment and are intended as representative views for reference only

MAGNETO

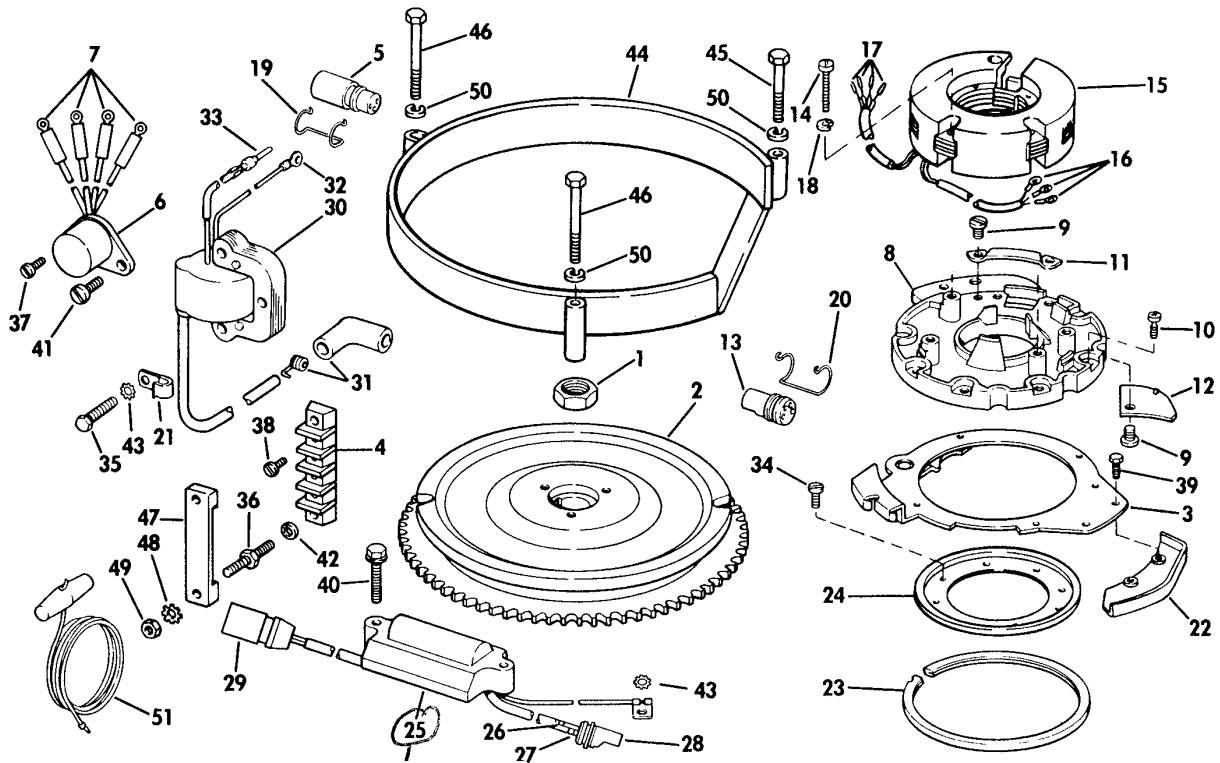

100SD

REF NO	PART NO	NAME OF PART	QTY PER ASSY	REF NO	PART NO	NAME OF PART	QTY PER ASSY
1	321341	NUT, Crankshaft	1	27	511072	CLIP	1
2	582014	FLYWHEEL ASSEMBLY	1	28	511449	CONNECTOR	1
3	388261	RETAINER & LINK ASSY	1	29	511450	CONNECTOR	1
4	511271	TERMINAL BLOCK	1	30	581861	COIL ASSY	2
5	511465	CONNECTOR	1	31	581027	COVER & TERMINAL	1
6	581778	RECTIFIER ASSEMBLY	1	32	510767	TERMINAL	1
7	510780	RING TERMINAL	4	33	511469	PIN, Contact	1
*	581631	PLATE ASSY COMPLETE	1	34	306286	SCREW, Support to cylinder	4
8	581854	PLATE & SLEEVE ASSY	1	35	309646	SCREW, Coil mounting	4
9	510193	SCREW, Clamp & cover	3	36	322164	SCREW, Terminal block mtg	2
10	511460	SCREW, Retainer	7	37	314576	SCREW, Rectifier mounting	1
11	511458	CLAMP, Leads	1	38	315003	SCREW, Terminal	4
12	511459	COVER, Leads	1	39	320468	SCREW, Throttle cam	2
13	511464	CONNECTOR, Leads	1	40	314951	SCREW, Power pack	2
14	132123	SCREW, Stator mounting	3	41	552421	SCREW, Rectifier to bracket	1
15	581651	STATOR ASSY	1	42	120052	LOCKWASHER, Terminal block	2
16	510780	TERMINAL	3	43	306488	LOCKWASHER	5
17	581656	SOCKET ASSY	4	44	388567	FLYWHEEL GUARD	1
18	120052	LOCKWASHER, Stator mtg	3	45	306493	SCREW, Guard	1
19	322548	RETAINER, Three terminal	1	46	306832	SCREW, Guard	2
20	322549	RETAINER, Four terminal	1	47	322166	COVER, Terminal block	1
21	309041	CLAMP, Coil leads	1	48	303916	LOCKWASHER, Cover	2
22	322979	CAM, Throttle control	1	49	204046	NUT, Terminal block cover	2
23	322435	BEARING, Plate to support	1	50	306396	LOCKWASHER, Guard screw	3
24	322102	SUPPORT	1	51	378347	EMERGENCY STARTER ROPE	1
25	581927	POWER PACK ASSY	1				
26	511071	CLIP	1				

* Not Shown

INDENTED PART NAMES INDICATE THAT THESE PARTS ARE INCLUDED IN PRECEDING ASSEMBLY
ORDER ALL PARTS FROM YOUR LOCAL AUTHORIZED DEALER

ELECTRIC STARTER & SOLENOID

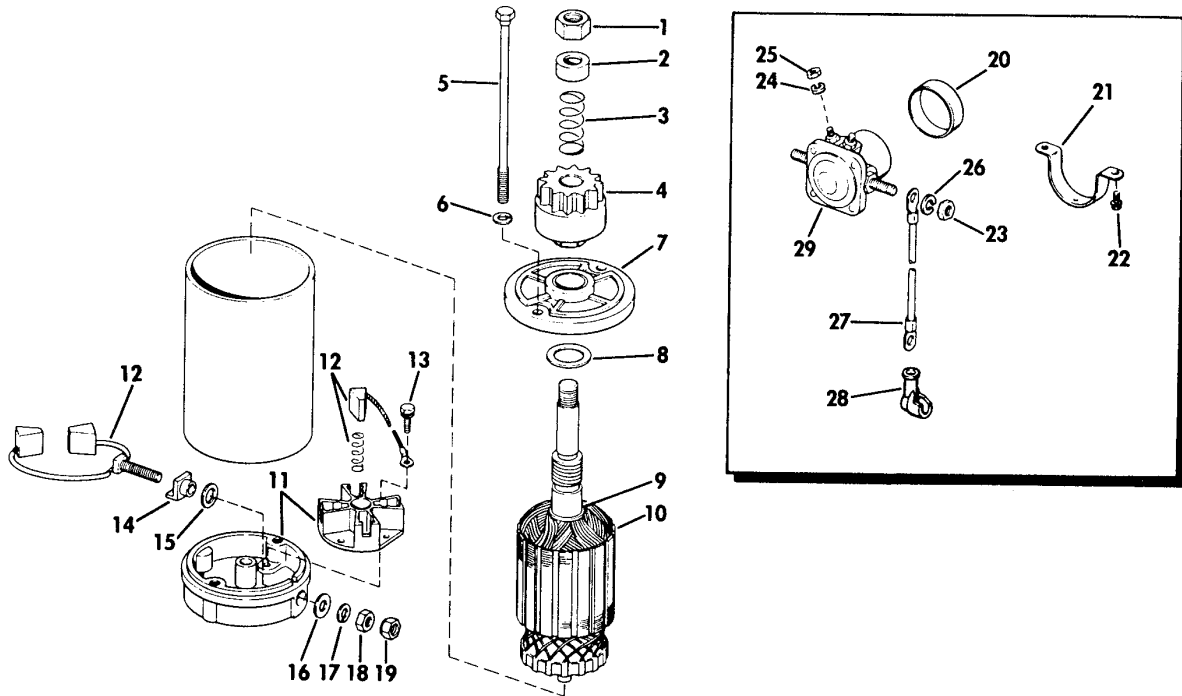

101SD

REF NO	PART NO	NAME OF PART	QTY PER ASSY	REF NO	PART NO.	NAME OF PART	QTY PER ASSY
*	388959	STARTER MOTOR ASSY	1	16	316749	WASHER, Plain	1
1	316740	NUT, Gear stop spacer	1	17	316744	LOCKWASHER	1
2	316741	SPACER, Stop gear	1	18	321642	NUT, Input stud	1
3	316742	SPRING, Anti drift	1	19	321641	LOCKNUT, Input stud	1
4	321648	DRIVE ASSY	1	20	311217	SLEEVE, Solenoid	1
5	387939	THRU BOLT PACKAGE	1	21	311218	CLAMP, Solenoid mtg	1
6	321646	LOCKWASHER	2	22	312889	SCREW, Solenoid mount	2
7	386639	CAP ASSY	1	23	311349	NUT, Terminal	4
8	316750	WASHER, Thrust	1	24	120052	LOCKWASHER, Terminal	2
9	321645	SNAP RING, Thrust	1	25	306556	NUT, Terminal	2
10	387766	ARMATURE	1	26	306325	LOCKWASHER, Terminal	3
11	387768	CAP ASSY, Commutator	1	27	388246	CABLE AND COVER ASSY	1
12	385952	BRUSH AND SPRING SET	1	28	322815	COVER	2
13	321643	BOLT	2	29	389398	SOLENOID ASSY	1
14	316743	BUSHING, Insulation	1				
15	316748	WASHER, Insulation	1				

* Not Shown

INDENTED PART NAMES INDICATE THAT THESE PARTS ARE INCLUDED IN PRECEDING ASSEMBLY

SPECIFY MODEL AND SERIAL NUMBER OF MOTOR WHEN ORDERING PARTS

INSTRUMENT & CABLE

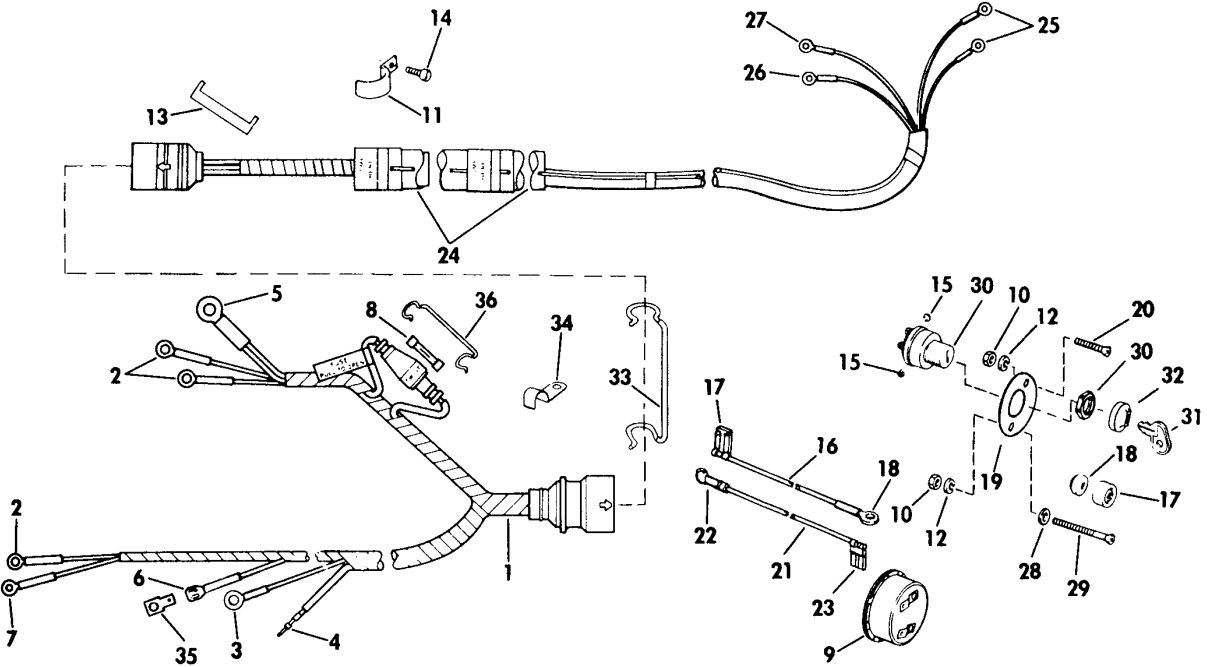

102SD

REF NO	PART NO.	NAME OF PART	QTY PER ASSY	REF NO.	PART NO.	NAME OF PART	QTY PER ASSY
1	389399	CABLE ASSY	1	18	510780	TERMINAL, Ring	1
2	204036	RING TERMINAL	3	19	323272	SWITCH PLATE	1
3	308294	RING TERMINAL	1	20	122481	SCREW, Dash panel	1
4	511469	PIN, CONTACT	1	21	581807	LEAD ASSY, Switch to horn	1
5	204053	RING TERMINAL	1	22	308808	TERMINAL	1
6	204034	TERMINAL	1	23	309437	TERMINAL	1
7	510780	TERMINAL	1	24	389495	INSTRUMENT CABLE ASSY	1
8	510884	FUSE, 20 amp	1	25	204037	TERMINAL, Ring	2
*	388869	INSTRUMENT & CABLE ASSY	1	26	510780	TERMINAL, Ring	2
9	389396	HORN ASSY	1	27	204039	TERMINAL, Ring	1
10	308644	NUT, Panel to horn bracket	6	28	323287	WASHER	1
11	304494	CLAMP, Cable to boat	4	29	323288	SCREW, Switch Plate	1
12	321447	LOCKWASHER	6	30	389397	SWITCH, Ignition	1
13	303806	TUBING	1	31	**	KEY, Ignition	2
14	305009	SCREW, Clamp to boat	4	32	322176	PUSH KNOB, Key	1
15	306559	SCREW, Starter switch	6	33	315182	CLAMP, Cable	1
16	581112	LEAD ASSY	1	34	315197	CLIP	1
17	309437	TERMINAL	1	35	121689	ADAPTER, Terminal	1
				36	321077	RETAINER, Fuse holder	2

* Not Shown

**See Service Bulletin for Key Ordering Information

INDENTED PART NAMES INDICATE THAT THESE PARTS ARE INCLUDED IN PRECEDING ASSEMBLY
ORDER ALL PARTS FROM YOUR LOCAL AUTHORIZED DEALER

CARBURETOR

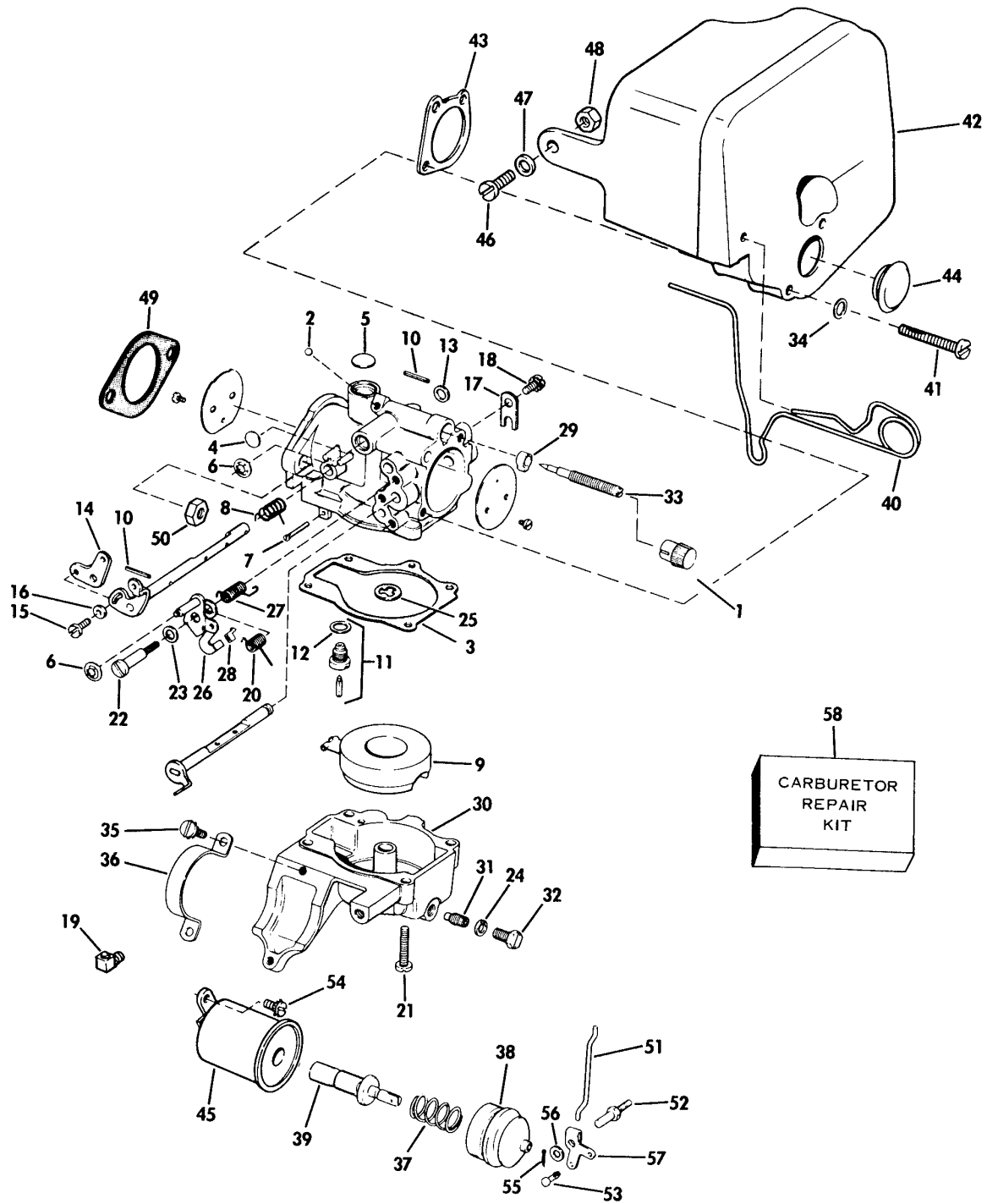

103SD

INDENTED PART NAMES INDICATE THAT THESE PARTS ARE INCLUDED IN PRECEDING ASSEMBLY
SPECIFY MODEL AND SERIAL NUMBER OF MOTOR WHEN ORDERING PARTS

CARBURETOR

REF NO	PART NO	NAME OF PART	QTY PER ASSY	REF NO	PART NO	NAME OF PART	QTY PER ASSY
*	389280	CARBURETOR ASSY	1	30	322645	FLOAT CHAMBER	1
1	323622	KNOB, Adjustment	1	31	319831	ORIFICE PLUG .	1
2	304201	LEAD SHOT	1	32	307832	SCREW PLUG	1
†3	316331	GASKET, Float bowl	1	33	388885	NEEDLE VALVE, Slow speed	1
†4	307542	CORE PLUG	2	34	306015	Washer .	2
†5	202310	CORE PLUG	1	35	303737	SCREW, Yoke to bracket	2
†6	313973	RETAINER	2	36	303740	YOKE, Solenoid	1
†7	302661	HINGE PIN, Float	1	37	320783	SPRING, Plunger	1
8	313357	SPRING, Throttle return	1	38	303792	COVER, Solenoid	1
†9	382363	FLOAT ASSY	1	39	377890	PLUNGER, Solenoid	1
10	303261	ROLL PIN, Shaft	2	40	322786	KNOB, Choke	1
†11	378895	FLOAT VALVE & SEAT ASSY.	1	41	322784	SCREW, Silencer to carb	2
†12	310996	GASKET	1	42	389081	AIR SILENCER	1
13	307596	WASHER, Throttle shaft	1	43	323338	GASKET, Carb to silencer	1
14	320287	ADJUSTMENT LEVER	1	44	316074	PLUG, Air silencer	1
15	510278	SCREW, Throttle lever	1	45	385554	SOLENOID	1
16	300803	WASHER	1	46	309483	SCREW, Air silencer	1
17	314906	CLIP, Choke shaft	1	47	306561	WASHER, Air silencer	1
18	311516	SCREW, Clip	1	48	307999	NUT, Air silencer	1
19	122510	ELBOW, Fuel line	1	†49	314477	GASKET, Carb to manifold	1
20	318445	SPRING, Choke override	1	50	316355	NUT, Carb mounting	2
21	310302	SCREW, Float bowl	4	51	315322	LINK	1
22	309720	SHOULDER SCREW	1	52	303739	PIVOT PIN	1
23	553645	WASHER, Bellcrank screw	1	53	382778	PIN, Solenoid shaft	1
†24	303630	WASHER, Screw plug	1	54	510193	SCREW, Choke lead	1
†25	316332	GASKET, Nozzle	1	55	305650	COTTER PIN	1
26	388494	BELLCRANK, Choke	1	56	307596	WASHER	1
27	315239	SPRING, Choke return	1	57	303747	LEVER, Shaft to link	1
28	318536	SLEEVE	1	58	388796	CARBURETOR REPAIR KIT	1
29	315232	RETAINER, Needle valve	1				

*Not Shown

†Also Available in Carburetor Repair Kit

INDENTED PART NAMES INDICATE THAT THESE PARTS ARE INCLUDED IN PRECEDING ASSEMBLY
ORDER ALL PARTS FROM YOUR LOCAL AUTHORIZED DEALER

INTAKE MANIFOLD

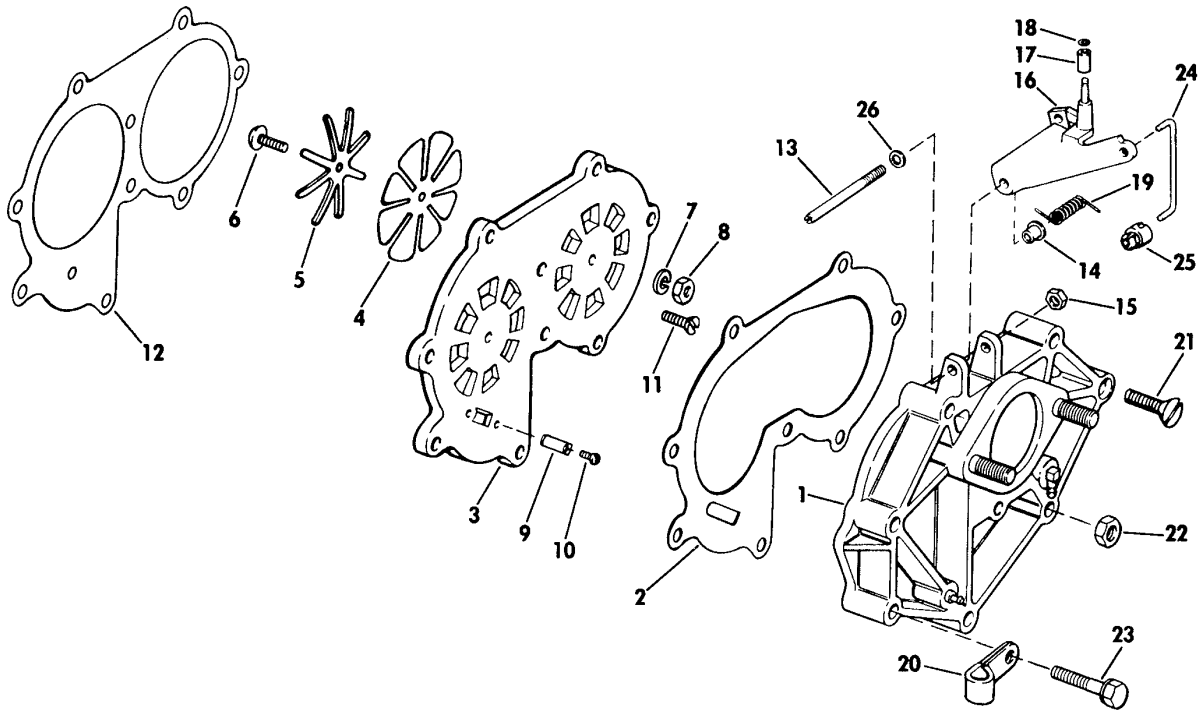

104SD

REF NO	PART NO	NAME OF PART	QTY PER ASSY	REF NO	PART NO	NAME OF PART	QTY PER ASSY
1	388584	MANIFOLD, Intake	1	14	315101	BUSHING, Follower pin	2
2	321573	GASKET, Manifold	1	15	304753	NUT, Follower pin	1
*	387655	LEAF PLATE ASSEMBLY	1	16	388677	CAM FOLLOWER	1
3	320155	PLATE, Leaf	1	17	305232	ROLLER, Cam follower	1
4	320154	LEAF VALVE	2	18	307529	RETAINING RING, Roller	1
5	311931	STOP, Leaf	2	19	320157	SPRING, Cam follower	1
6	301858	SCREW, Leaf to plate	2	20	321084	CLAMP, Fuel line	1
7	306546	LOCKWASHER, Leaf screw	2	21	304294	SCREW, Manifold to crankcase	1
8	306556	NUT, Leaf screw	2	22	306338	NUT, Manifold to crankcase	5
9	309466	VALVE, Drain	1	23	303459	SCREW, Manifold to crankcase	2
10	303761	SCREW, Valve	1	24	320150	LINK, Carb to cam follower	1
11	307609	SCREW, Plate to crankcase	1	25	313329	RETAINER, Link throttle lever	2
12	321479	GASKET, Plate to crankcase	1	26	551953	WASHER	3
13	320318	PIN, Cam follower	1				

*Not Shown

INDENTED PART NAMES INDICATE THAT THESE PARTS ARE INCLUDED IN PRECEDING ASSEMBLY

SPECIFY MODEL AND SERIAL NUMBER OF MOTOR WHEN ORDERING PARTS

CRANKSHAFT & PISTON

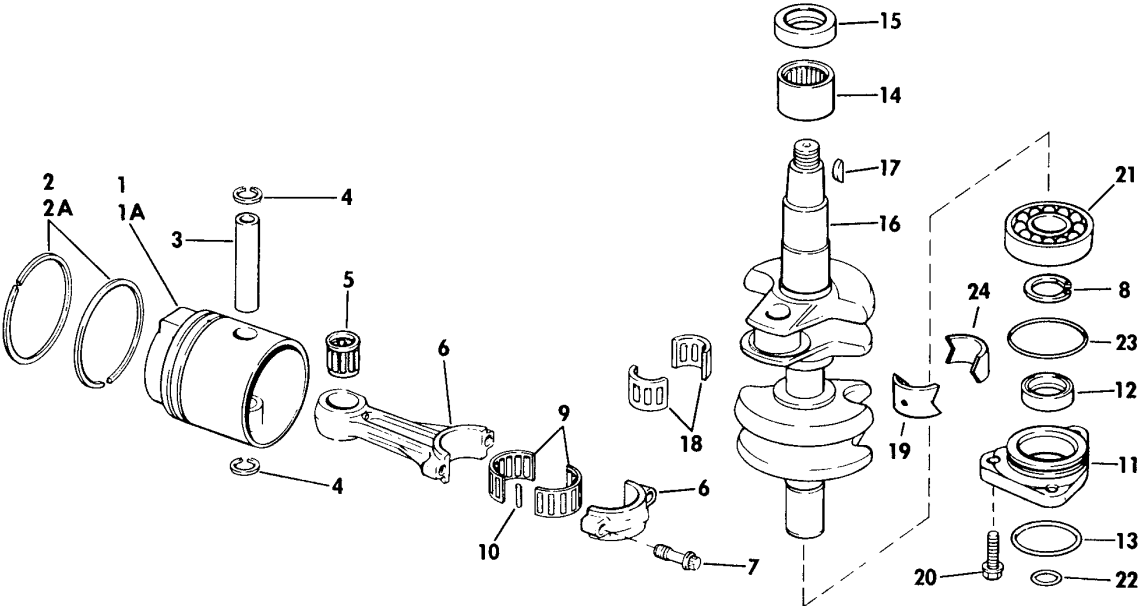

105SD

REF NO	PART NO	NAME OF PART	QTY PER ASSY	REF NO	PART NO	NAME OF PART	QTY PER ASSY
1	389155	PISTON, Standard	2	12	319664	SEAL	2
2	385807	RING SET, Standard	2	13	322224	O-RING	1
1A	388424	PISTON, 030 O S	2	14	386481	ROLLER BEARING ASSY	1
2A	385809	RING SET, 030 O S	1	15	321504	SEAL	1
3	553742	WRIST PIN	2	16	388878	CRANKSHAFT	1
4	302577	RETAINING RING	4	17	307480	KEY, Crankshaft	1
5	378251	BEARING, Wrist pin	2	18	389613	RETAINER & NEEDLES, Ctr	2
6	387465	CONNECTING ROD ASSY	2	19	322916	BEARING LINER, Ctr main, cylinder	1
7	308186	SCREW, Rod Cap	2	20	321527	SCREW	3
8	305160	RETAINING RING	1	21	386482	ROLLER BEARING ASSY	1
9	388188	RETAINER ASSY	2	22	553127	O-RING	1
10	387142	NEEDLE SET	2	23	319662	SEAL	1
11	388285	CRANKCASE HEAD & SEAL	1	24	322915	BEARING LINER, Ctr main, crankcase	1

INDENTED PART NAMES INDICATE THAT THESE PARTS ARE INCLUDED IN PRECEDING ASSEMBLY
ORDER ALL PARTS FROM YOUR LOCAL AUTHORIZED DEALER

CYLINDER & CRANKCASE

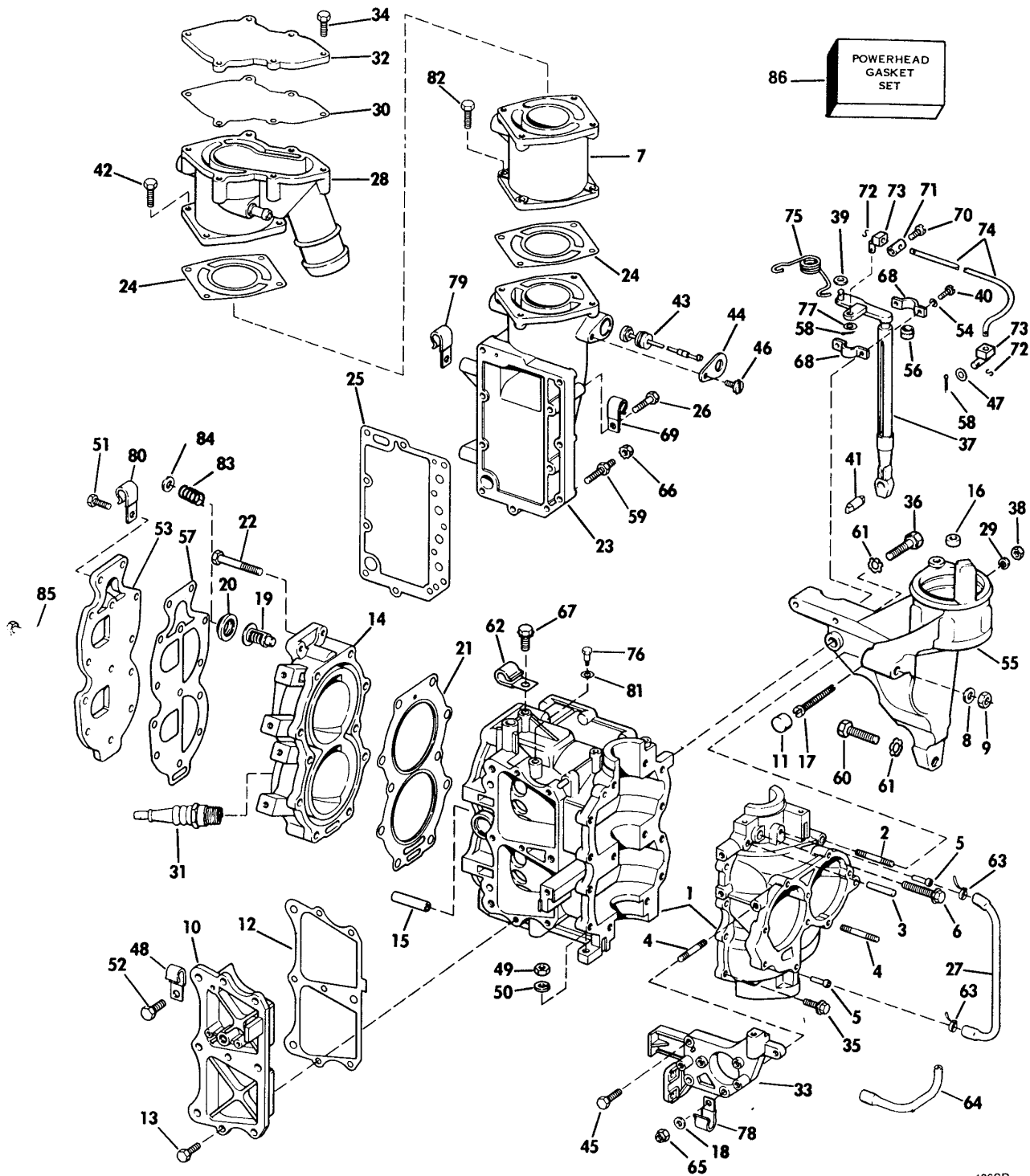

ES NO	PAINT	SPRAY	1 QT CAN
209	PRIMER	172757	376015
391	WHITE	172748	385300
1110	BLUE	172836	N/A

106SD

INDENTED PART NAMES INDICATE THAT THESE PARTS ARE INCLUDED IN PRECEDING ASSEMBLY
SPECIFY MODEL AND SERIAL NUMBER OF MOTOR WHEN ORDERING PARTS

CYLINDER & CRANKCASE

REF NO	PART NO	NAME OF PART	QTY. PER ASSY	REF NO	PART NO	NAME OF PART	QTY PER ASSY
1	388832	CYLINDER & CRANKCASE ASSY	1	43	386686	TEMPERATURE SWITCH	1
2	308354	STUD, Starter bracket	1	44	322300	COVER, Temperature Switch	1
3	305070	TAPER PIN	1	45	302030	SCREW, Bracket	1
4	308353	STUD	7	46	303311	SCREW, Switch cover	1
5	303423	NIPPLE, Oil hose	2	47	551953	WASHER, Pivot pin	1
6	318622	SCREW, Cyl to crankcase	6	48	310947	CLAMP, Motor cable to cover	1
7	322180	EXTENSION, Manifold	1	49	306422	NUT, Powerhead to hsg stud	2
8	306482	WASHER, Starter mtg brkt	1	50	311388	LOCKWASHER	2
9	308355	NUT, Starter bracket	1	51	300646	SCREW, Cyl head cover	12
10	322848	BY-PASS COVER ASSY	1	52	306450	SCREW, By-pass cover	3
11	314416	BUMPER, Spark adj screw	1	53	323583	COVER, Cylinder head	1
12	319661	GASKET, By-pass cover	1	54	120052	LOCKWASHER	2
13	300646	SCREW, By-pass cover	6	55	320012	BRACKET, Port	1
14	323585	CYLINDER HEAD	1	56	320524	BEARING, Control lever	1
15	318357	WATER DEFLECTOR	2	57	319665	GASKET, Water cover	1
16	304847	SEAL, Starter to bracket	2	58	303049	COTTER PIN	2
17	317615	SCREW, Spark Adj	1	59	311328	BOLT, Instrument cable	1
18	306482	WASHER, Bracket	2	60	306418	SCREW, Starter bracket	1
19	378065	THERMOSTAT	1	61	306396	LOCKWASHER	2
20	323582	SEAL, Thermostat	1	62	261598	CLAMP, Motor cable	1
21	319633	GASKET, Cylinder head	1	63	320107	CLAMP, Hose	4
22	305027	SCREW, Cylinder head	10	64	322978	HOSE, Manf to c'case, lower	1
23	388195	MANIFOLD & NIPPLE, Lower	1	65	308355	NUT, Bracket	2
24	322278	GASKET, Manifold	2	66	316659	NUT, Cable ground	1
25	319578	GASKET, Exhaust cover	1	67	308936	SCREW, Clamp	1
26	306778	SCREW, Exhaust manifold to cylinder, 1-3/8"	9	68	320523	BEARING CLAMP	2
26	316907	SCREW, Exh manifold to cylinder, 2-3/4"	1	69	309322	CLAMP . .	2
27	322977	HOSE, Mfld to crankcase	1	70	304221	SCREW	1
28	388205	MANIFOLD & NIPPLE, Upper	1	71	304222	COLLAR	1
29	306396	LOCKWASHER, Spark adj	1	72	307565	PIN, Rod, pivot pin	2
30	322279	GASKET, Manifold to cover	1	73	320786	PIVOT PIN	2
†31	389131	SPARK PLUG, Champion L81Y	2	74	320156	ROD, Throttle control	1
32	322168	COVER, Upper manifold	1	75	321721	SPRING . .	1
33	323791	BRACKET, Starboard	1	76	315092	SCREW, Lockout lever boss	1
34	300646	SCREW, Cover to manifold	6	77	305831	WASHER, Pivot pin	1
35	314979	SCREW, Cylinder to c'case	8	78	310441	CLAMP	1
36	306778	SCREW, Starter bracket	1	79	311339	CLAMP	1
37	386464	CONTROL LEVER & PIN	1	80	310439	CLAMP, Connector	1
38	304753	NUT, Spark adj	1	81	310540	WASHER, Lever boss	1
39	305831	WASHER	1	82	307604	SCREW	8
40	510338	SCREW, Bearing clamp	2	83	323586	SPRING, Pressure relief	1
41	304155	PIN, Control lever	1	84	324314	RETAINER, Thermostat scal	1
42	306409	SCREW, Manifold	4	85	308742	SCREW, Cover	1
				86	389078	POWER HEAD GASKET SET	1

†Set gap at 045

INDENTED PART NAMES INDICATE THAT THESE PARTS ARE INCLUDED IN PRECEDING ASSEMBLY
ORDER ALL PARTS FROM YOUR LOCAL AUTHORIZED DEALER

INTERMEDIATE HOUSING

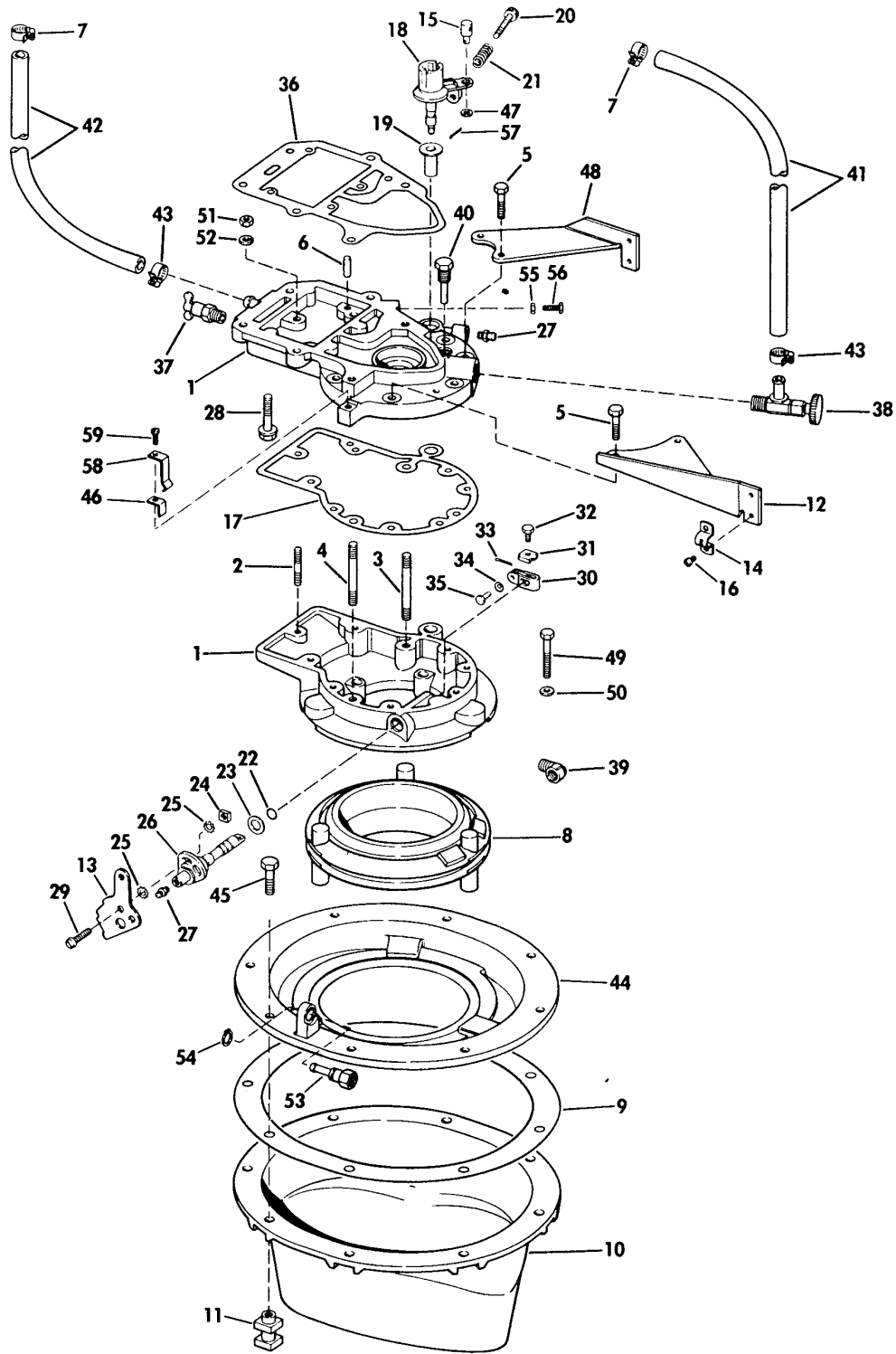

107SD

INDENTED PART NAMES INDICATE THAT THESE PARTS ARE INCLUDED IN PRECEDING ASSEMBLY
SPECIFY MODEL AND SERIAL NUMBER OF MOTOR WHEN ORDERING PARTS

INTERMEDIATE HOUSING

REF NO	PART NO	NAME OF PART	QTY PER ASSY	REF NO	PART NO	NAME OF PART	QTY PER ASSY
1	389451	ADAPTER & INTERMEDIATE HOUSING ASSY.	1	29	552062	SCREW, Shift lever adjustment	2
2	313942	STUD, Hsg. to adapter, 1-1/2" long	1	30	322092	LEVER, Shift rod.	1
3	322283	STUD, Hsg. to adapter & powerhead, 2-3/4" long	1	31	319537	CLIP, Shift rod lever	1
4	908272	STUD, Hsg to adapter & powerhead, 2-1/2" long	1	32	321532	SCREW, Lever clip	1
5	324474	SCREW, Adapter to intermediate housing	7	33	306376	COTTER PIN, Shift rod to lever	1
6	318026	DOWEL	2	34	304380	BOW WASHER, Shift rod to lever	1
7	980863	CLAMP, Hose, Adapter to manifold	2	35	319541	PIN, Shift rod to lever	1
8	322214	SEAL, Mounting plate to motor	1	36	319710	GASKET, Adapter to powerhead	1
9	322242	SEAL, Plate to motor mount	1	37	379957	PETCOCK ASSY., Water drain (fwd)	1
10	388409	MOTOR MOUNT ASSY	1	38	388239	SHUT-OFF VALVE, Adapter	1
11	322304	NUT, Mount plate to motor mount	8	39	310924	FITTING, Fuel inlet	1
12	322255	SUPPORT, Shift cable	1	40	388238	PLUG & ANODE, Adapter	1
13	322225	SHIFT LEVER	1	41	322223	HOSE, Shut-off valve to exhaust manifold, upper	1
14	322557	CLAMP, Cable	2	42	322222	HOSE, Adapter nipple to exhaust manifold, lower	1
15	322558	CONNECTOR	2	43	316832	CLAMP, Water hose	2
16	304904	SCREW, Clamp to support	4	44	322297	MOUNT PLATE	1
17	322281	GASKET, Adapter to intermediate housing	1	45	308429	SCREW, Mount plate to motor mount	8
18	388439	THROTTLE CONTROL	1	46	303700	SUPPORT	1
19	303854	BUSHING, Control gear	1	47	553146	WASHER, Connector	2
20	304573	SCREW, Idle adjustment	1	48	322254	SUPPORT, Throttle cable	1
21	309247	SPRING, Adjustment screw	1	49	552957	SCREW, Intermediate hsg to gearcase — 2-5/8" long	2
22	303191	O-RING, Shift lever shaft	2	49	316109	SCREW, Intermediate hsg to gearcase — 1-3/4" long	3
23	303775	WASHER, Lever to intermediate housing	1	50	552914	WASHER, Hsg to gearcase screw	5
24	203688	NUT, Adjustment screw	2	51	306388	NUT, Stud, adapter to intermediate housing	1
25	303480	LOCKWASHER, Adjustment screw	4	52	302290	LOCKWASHER, Stud, adapter to intermediate housing	1
26	388655	ADJUSTMENT LEVER & SHAFT ASSY	1	53	322560	FUEL FITTING	1
27	313607	FITTING, Lubrication	2	54	313236	RETAINING RING	1
28	314360	SCREW, Adapter to powerhead, 1-3/16" long	4	55	204046	NUT	1
28	318622	SCREW, Adapter to powerhead, 1-9/16" long	2	56	304015	SCREW, Adjustment	1
				57	302858	COTTER PIN, Connector	2
				58	303466	DETENT	1
				59	306478	SCREW	1

INDENTED PART NAMES INDICATE THAT THESE PARTS ARE INCLUDED IN PRECEDING ASSEMBLY

ORDER ALL PARTS FROM YOUR LOCAL AUTHORIZED DEALER

GEARCASE

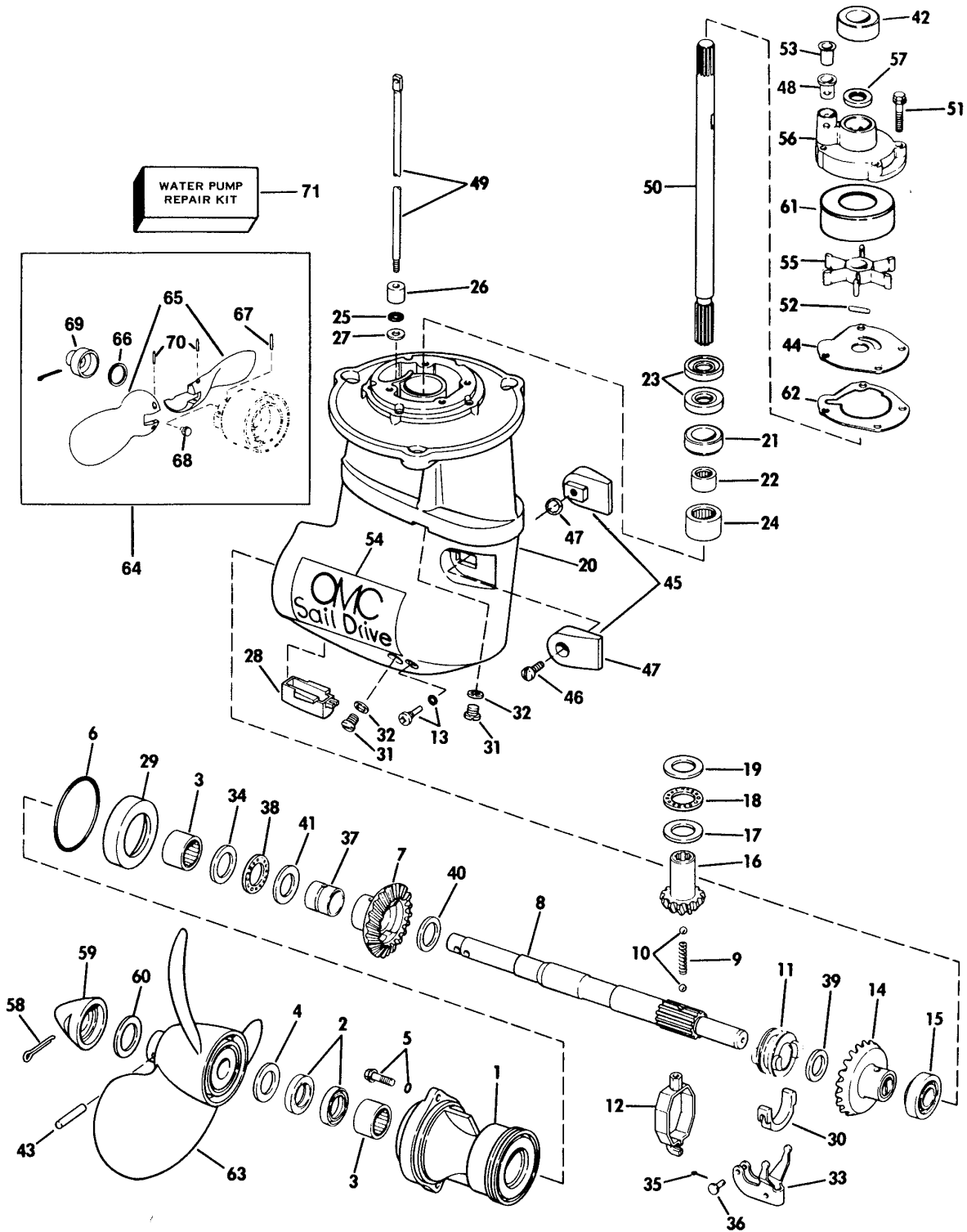

108SD

INDENTED PART NAMES INDICATE THAT THESE PARTS ARE INCLUDED IN PRECEDING ASSEMBLY
SPECIFY MODEL AND SERIAL NUMBER OF MOTOR WHEN ORDERING PARTS

GEARCASE

REF NO	PART NO.	NAME OF PART	QTY PER ASSY.	REF NO.	PART NO	NAME OF PART	QTY. PER ASSY
*	388874	GEARCASE ASSY	1	36	302504	PIN, Shift lever	1
1	388298	BEARING HOUSING & SEAL	1	37	319635	BUSHING, Reverse gear	1
2	321453	OIL RETAINER	2	38	388027	THRUST BEARING, Reverse gear	1
3	376856	BEARING ASSY , Prop shaft	2	39	319686	THRUST WASHER, Front	1
4	322234	WASHER, Seal	1	40	319685	THRUST WASHER, Rear	1
5	304071	SCREW	2	41	322747	THRUST WASHER, Reverse gear	1
*	317178	O-RING	1	42	322311	GROMMET, Impeller housing	1
6	313893	O-RING, Bearing housing	1	43	304575	DRIVE PIN, Propeller	1
7	323096	GEAR, Reverse	1	†44	323333	PLATE, Impeller housing	1
8	388194	PROPELLER SHAFT	1	45	389999	ANODE ASSY	1
9	323278	SPRING, Detent	1	46	306461	SCREW, Anodes to gearcase	1
10	316506	BALL, Detent	2	47	309776	LOCKWASHER	2
11	319565	SHIFTER, Clutch dog	1	48	302497	GROMMET, Housing	1
12	386744	SHIFTER YOKE AND CONNECTOR	1	49	322216	SHIFT ROD.	1
13	308376	PIVOT PIN, Shifter lever	1	50	323331	DRIVESHAFT	1
14	388729	GEAR & BUSHING ASSY , Fwd	1	†51	323310	SCREW, Impeller housing	1
15	386186	ROLLER BEARING, Fwd gear	1	†52	300611	PIN, Impeller	1
16	323095	PINION, Driveshaft	1	53	308053	BUSHING, Impeller housing grommet	1
17	322688	THRUST WASHER, Bearing	1	54	322482	TRANSFER, Gearcase	2
18	388027	THRUST BEARING, Pinion	1	†55	388702	IMPELLER ASSY	1
19	319667	THRUST WASHER	1	56	389104	IMPELLER HOUSING & SEAL	1
20	388293	GEARCASE, Bearing & seal	1	†57	321786	SEAL, Impeller housing	1
21	322018	BEARING HOUSING	1	58	306394	COTTER PIN	1
22	386473	BEARING ASSY	1	59	305294	NUT, Propeller	1
23	321928	SEAL ASSY	2	60	304576	THRUST WASHER	1
24	376856	BEARING ASSY	1	†61	323008	CUP, Impeller housing	1
25	301877	O-RING, Bushing	1	†62	323311	GASKET, Housing plate	1
26	321736	BUSHING, Shift rod	1	63	389093	PROPELLER 12 x 8	1
27	321738	WASHER, Shift rod bush	1	64	389961	PROPELLER, Folding	1
28	322217	SCREEN, Intake	1	65	324924	BLADE, Propeller	2
29	322363	SPACER, Shift yoke	1	66	324926	THRUST WASHER	1
30	321512	CRADLE, Clutch dog	1	67	324927	DRIVE PIN, propeller	1
31	307551	PLUG & WASHER	2	68	324928	SET SCREW	2
32	311598	WASHER	1	69	324929	RETAINER	1
33	320118	LEVER, Shifting	1	70	324930	PIN	2
34	319667	THRUST WASHER	1	71	389105	WATER PUMP REPAIR KIT	1
35	306376	COTTER PIN	1				

* Not shown

† Contents of Water Pump Repair Kit

INDENTED PART NAMES INDICATE THAT THESE PARTS ARE INCLUDED IN PRECEDING ASSEMBLY
ORDER ALL PARTS FROM YOUR LOCAL AUTHORIZED DEALER

ALTERNATOR KIT

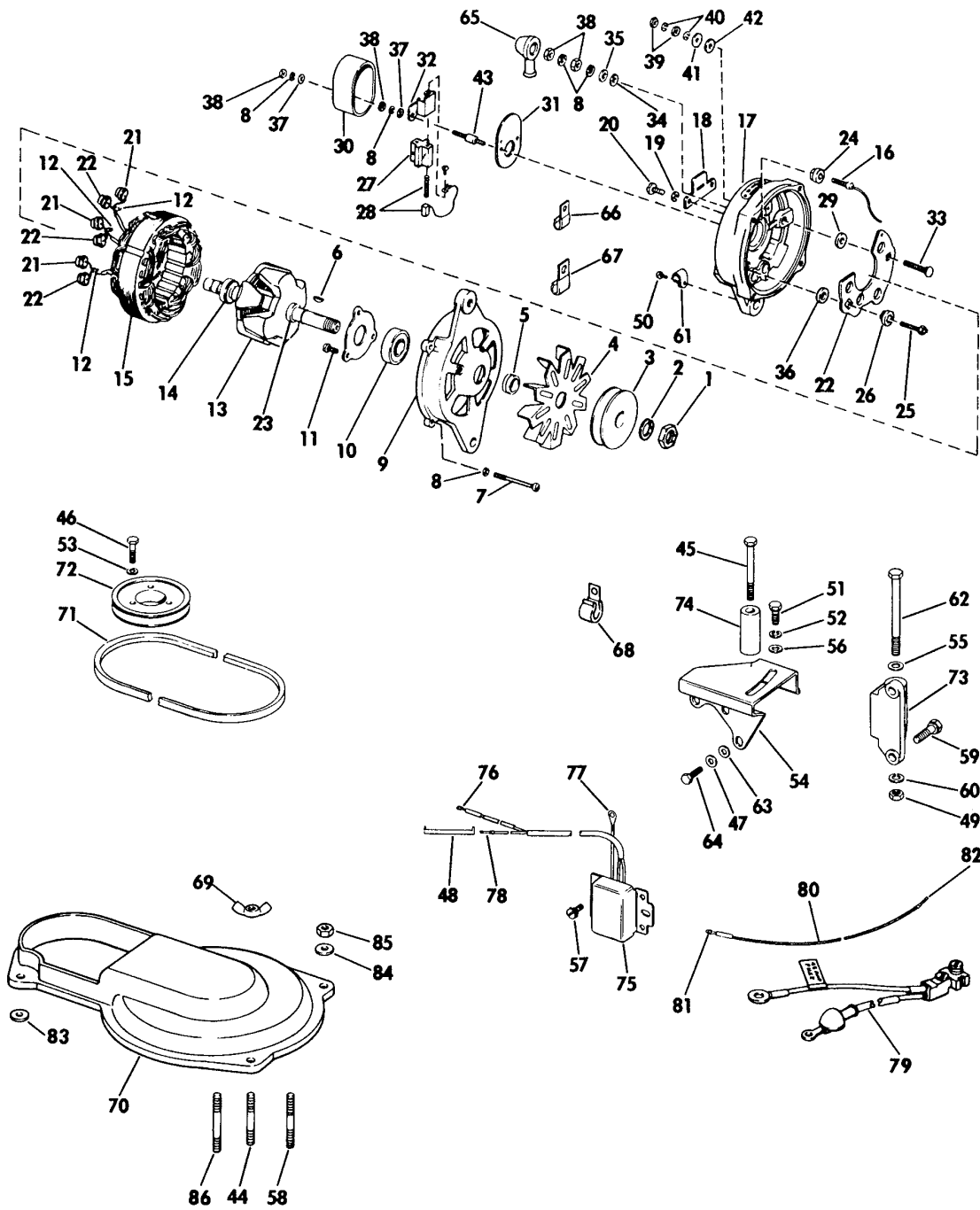

109SD

INDENTED PART NAMES INDICATE THAT THESE PARTS ARE INCLUDED IN PRECEDING ASSEMBLY
SPECIFY MODEL AND SERIAL NUMBER OF MOTOR WHEN ORDERING PARTS

ALTERNATOR KIT

REF NO	PART NO	NAME OF PART	QTY PER ASSY	REF NO	PART NO	NAME OF PART	QTY PER ASSY
★ ★	388196	ALTERNATOR KIT ASSY	1	51	306322	SCREW, Bracket	1
▲ ★	388331	ALTERNATOR KIT ASSY	1	52	306325	LOCKWASHER, Bracket	1
*	981186	ALTERNATOR ASSY, COMP	1	53	306396	LOCKWASHER, Pulley	3
1	311311	NUT, Rotor shaft	1	★ 54	322165	ADJUSTMENT BRACKET	1
2	311316	LOCKWASHER, Rotor shaft	1	▲ 54	322403	ADJUSTMENT BRACKET	1
3	311312	PULLEY, Drive	1	55	306405	WASHER	4
4	316266	FAN, Ventilating	1	56	306453	WASHER	2
5	316267	SPACER, Rotor shaft	1	57	303311	SCREW, Reg to manifold	2
6	311315	KEY, Rotor shaft	1	58	311328	STUD, Bracket	1
7	980184	THRU BOLT PACKAGE	1	59	306835	SCREW, Bracket to manifold	2
8	120052	LOCKWASHER	10	60	309336	LOCKWASHER	1
9	381468	HEAD ASSY, Drive end	1	61	310503	CLAMP, Leads	1
10	380207	BRG ASSY, Drive end	1	62	311391	SCREW	1
11	304608	SCREW, Retainer	3	63	311734	WASHER	2
12	382009	EYELET PACKAGE	1	★ 64	313332	SCREW, Adj bracket	3
13	981182	ROTOR & BEARING ASSY	1	65	314902	COVER, Lead	1
14	383900	SLIP RING & BRG PKG	1	★ 66	316386	CLAMP, Lead	1
15	382003	STATOR ASSEMBLY	1	67	316993	CLAMP, Leads to bracket	1
16	+	STUD, Field terminal	1	▲ 68	309846	CALBE CLAMP	1
17	981183	HEAD ASSY, Slip ring end	1	69	405644	WING NUT	3
18	**	INSULATION, Slip ring end	1	★ 70	322886	BELT GUARD	1
19	**	LOCKWASHER, Insul 10	2	▲ 70	322897	BELT GUARD	1
20	**	SCREW, Insul, 10-32	2	▲ 71	322480	V-Belt, 34"	1
21	980294	RECTIFIER, Negative	3	★ 71	322325	V-BELT, 26"	1
22	383897	RECTIFIER & PLATE ASSY	1	72	322326	PULLEY, Flywheel	1
23	312487	RETAINER, Felt washer	1	★ 73	322342	ALTERNATOR BRACKET	1
24	+	BUSHING, Insul, field term	1	▲ 73	907798	ALTERNATOR BRACKET	1
25	+	STUD, Auxiliary, terminal	1	★ 74	322324	SPACER, Adj bracket	1
26	+	BUSH, Insulation, aux term	1	75	383440	VOLTAGE REGULATOR	1
27	382005	BRUSH HOLDER ASSY	1	76	204036	RING TERMINAL	1
28	980084	BRUSH & SPRING SET	1	77	308294	RING TERMINAL	1
29	+	BUSH, Insul, battery term	1	78	308808	KNIFE DISCONNECT	1
30	909127	COVER, Slip ring	1	79	581967	FUSE & LEAD ASSY	1
31	313047	PLATE, Back-up, brush holder	1	80	581968	LEAD ASSY	1
32	**	COVER, Brush holder	1	81	510780	RING TERMINAL	1
33	+	STUD, Battery terminal	1	82	308808	TERMINAL	1
34	+	WASHER, Insul, field term	1	83	302401	WASHER, Belt guard	5
35	+	WASHER, Plain, fld & auxiliary terminal	2	84	306358	WASHER, Adj bracket	2
36	+	WASHER, Insul, aux term	1	85	301472	NUT, Adj bracket	1
37	306547	WASHER, Mounting stud	4	86	322888	STUD, Guard to bracket	1
38	309485	NUT, Hex	8				
39	**	NUT, Battery term, 1/4-28	2				
40	**	LOCKWASHER, Bat term, 1/4"	2				
41	+	WASHER, Plain, bat term	1				
42	+	WASHER, Insul, bat term	1				
43	909174	STUD, Cover, slip ring	1				
44	908824	STUD, Guard to bracket	1				
★ 45	301438	SCREW	1				
46	302288	SCREW, Pulley	3				
47	302471	WASHER	3				
48	303806	TUBING, Voltage regulator	1				
49	303889	NUT, Alternator bracket	1				
50	306158	SCREW, Clamp	1				

* Not Shown ** No Part Number ★ High Mount ▲ Low Mount
 Available in Terminal Stud and Parts Package, Order Part #383899

INDENTED PART NAMES INDICATE THAT THESE PARTS ARE INCLUDED IN PRECEDING ASSEMBLY
ORDER ALL PARTS FROM YOUR LOCAL AUTHORIZED DEALER

PRIMER PUMP KIT

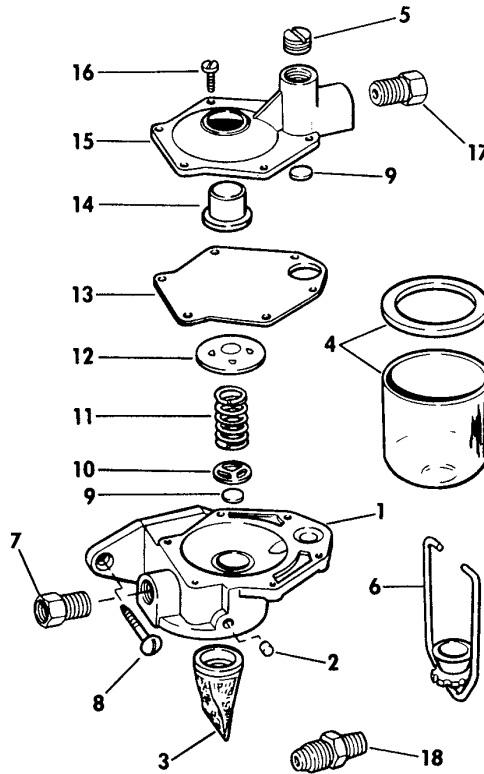

110SD

REF NO	PART NO	NAME OF PART	QTY PER ASSY	REF NO	PART NO	NAME OF PART	QTY PER ASSY
1	389687	PRIMER PUMP KIT ASSY	1	10	303420	RETAINER, Valve	1
2	305243	PLUG, Core	1	11	301803	SPRING	1
3	305185	FILTER	1	12	305714	SUPPORT	1
4	388480	BOWL AND SEAL	2	13	305716	DIAPHRAGM	1
5	324076	PLUG, Pipe	1	14	305713	BUTTON, Push	1
6	389686	THUMB NUT & YOKE ASSY	1	15	305717	HOUSING	1
7	908923	FITTING, Outlet	1	16	306431	SCREW	6
8	303675	SCREW, Wood	2	17	909261	FITTING, Inlet	1
9	303614	VALVE, Disc	2	18	173275	ANTI SYPHON VALVE	1

INDENTED PART NAMES INDICATE THAT THESE PARTS ARE INCLUDED IN PRECEDING ASSEMBLY

SPECIFY MODEL AND SERIAL NUMBER OF MOTOR WHEN ORDERING PARTS

FUEL PUMP

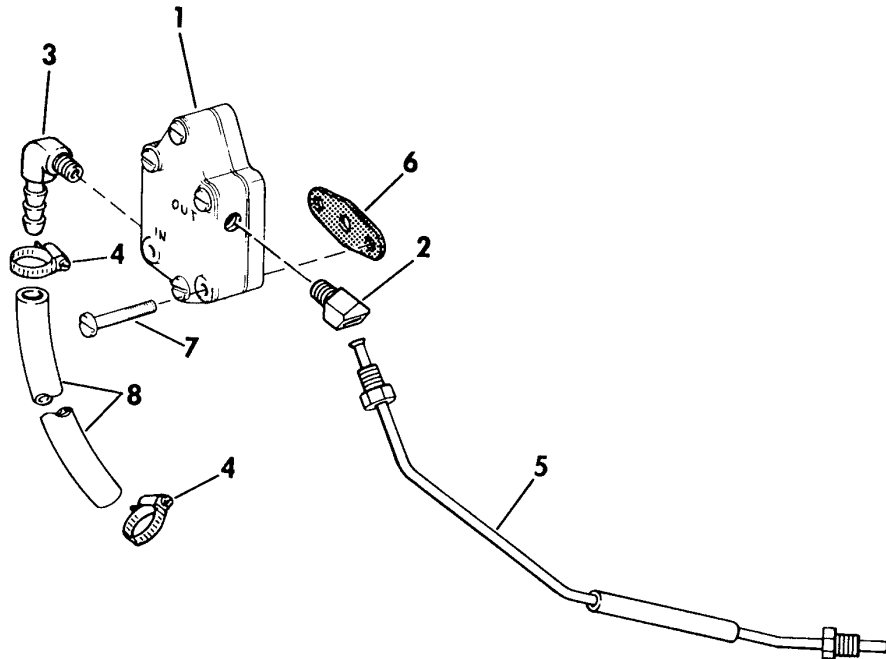

111SD

REF NO	PART NO	NAME OF PART	QTY PER ASSY
1	388527	FUEL PUMP ASSEMBLY	1
2	908993	ELBOW, Outlet	1
3	322706	ELBOW, Inlet	1
4	316832	CLAMP Hose	2
5	388592	FUEL LINE ASSY	1
6	303615	GASKET, Pump mounting	1
7	312330	SCREW, Pump mounting	2
8	322885	HOSE, Pump to nipple	1

** Cut From 25' Roll 322725

INDENTED PART NAMES INDICATE THAT THESE PARTS ARE INCLUDED IN PRECEDING ASSEMBLY
ORDER ALL PARTS FROM YOUR LOCAL AUTHORIZED DEALER

OMC STERN DRIVE

A DIVISION OF OUTBOARD MARINE CORPORATION
3145 CENTRAL AVENUE ■ WAUKEGAN, ILLINOIS ■ 60085 ■ PHONE 312-689-5700

PART NO 389181
SDL 3083

LITHO U S A